





ALL-CLEAR PHOTOSYSTEM (2 Wire) OWNER INSTALLATION AND USER MANUAL

 WARNING	AN AUTOMATIC GARAGE DOOR SYSTEM POSES A THREAT OF INJURY OR EVEN DEATH. INSTALL THE ALL-CLEAR PHOTOSYSTEM NO HIGHER THAN 4" - 6" ABOVE THE GARAGE FLOOR TO REDUCE THE RISK TO SMALL CHILDREN.
---	--

 WARNING	RISK OF ENTRAPMENT. DISCONNECT POWER TO THE OPENER BEFORE AND DURING INSTALLATION OF THIS ACCESSORY. DO NOT RECONNECT POWER TO OPENER UNTIL INSTRUCTED TO DO SO. ENSURE DOORWAY IS CLEAR BEFORE STARTING TESTING OF UNIT.
---	--

BEFORE STARTING THE INSTALLATION READ THESE INSTRUCTIONS AND THE INSTRUCTIONS FURNISHED WITH THE RESIDENTIAL GARAGE DOOR OPENER TO

STEP 1: Mark the position of the ALL-CLEAR™ Photosystem as follows: Mark a line on the left and right door jamb (close to the door track) **FOUR (4) inches AND SIX (6) inches** above the floor. *The top mark is the maximum height and the bottom line is the minimum height that the photosystem accessory can be placed.*

STEP 2: Mount the Photosystem "L" Brackets as follows:

- A. Remove the four mounting brackets from the package. Temporarily place the "U" shaped brackets, one around the receiver (unit with window and red LED) and one around the transmitter. **NOTE:** *It is easier to slip the photosystem units in from the side of the bracket than forcing them in from the front of the bracket.*
- B. Your photosystem assembly is provided with a universal bracket set. Using either the transmitter or receiver (window up towards the ceiling), hold the "L" bracket and the "U" bracket set together while moving them in between the limit marks on the door jamb. Continue to move the photosystem assembly within the limit marks until it clears the door hardware. *See Illustration, left.* Check to ensure the **WINDOW ON THE FRONT OF THE PHOTOSYSTEM UNIT IS WITHIN THE LIMIT MARKS ON THE DOOR JAMB.**
- C. Place a mark in the center of the lag screw elongated mounting hole. Measure its position and place a similar mark on the opposite door jamb. The brackets may be temporarily mounted to the jamb with a 1" flat head nail (provided) using the small hole above the slot. Using two 5/16" X 1-1/2" lag screws (provided), permanently mount the "L" bracket to both door jambs.

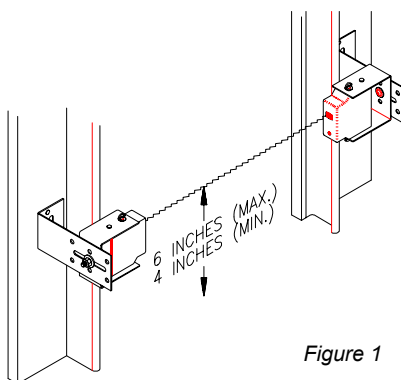

Figure 1

★ INSTALLATION OF ALL-CLEAR™ PHOTOSYSTEM

STEP 3: Connect the Photosystem as follows:

A. Remove the transmitter and receiver from their "U" mounting brackets.

Refer to Figures 2 through 4 for various wiring options for the All-Clear™ Photosystem. Steps B and C, below, describe the wiring for Series Connection with Receiver First, as illustrated in Figure 2.

- B. Run a wire pair (not supplied) around the garage door jamb between the transmitter and receiver "L" mounting brackets. **NOTE:** Leave about 12" of extra wire at each end. Use a minimum 22 gauge solid "trace" wire for interconnect.
- C. Run a wire pair (20 or 22 gage solid wire) from the receiver position (unit with "LED" light in the front, may be either side of the door) back to the rear bulkhead of the garage door opener. **NOTE:** Leave about 12" of extra wire at the receiver end and about 24" of extra wire at the opener end.
- D. Strip approximately 5/16" from each wire end at the photosystem units and at the opener.
- E. Using two (2) wire nuts (supplied), connect the wire ends at the All-Clear™ Photosystem transmitter to the pigtail wire ends coming out of the transmitter unit. *Although not required, it is recommended to connect the trace wire ends together and the unmarked wire ends together.*
- F. Using two (2) wire nuts (supplied), connect the wire ends at the All-Clear™ Photosystem receiver to the pigtail wire ends coming out of the receiver unit. *Although not required, it is recommended to connect the trace wire ends together and the unmarked wire ends together.*

108971

PHOTOCELL SERIES CONNECTION (RECEIVER FIRST)

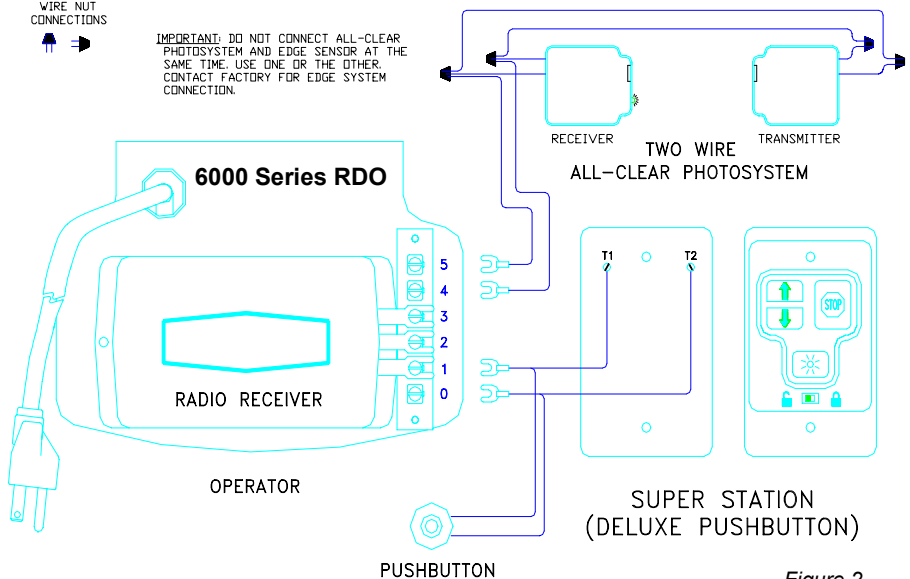

Figure 2

INSTALLATION OF ALL-CLEAR™ PHOTOSYSTEM

PHOTOCELL SERIES CONNECTION (TRANSMITTER FIRST)

108971

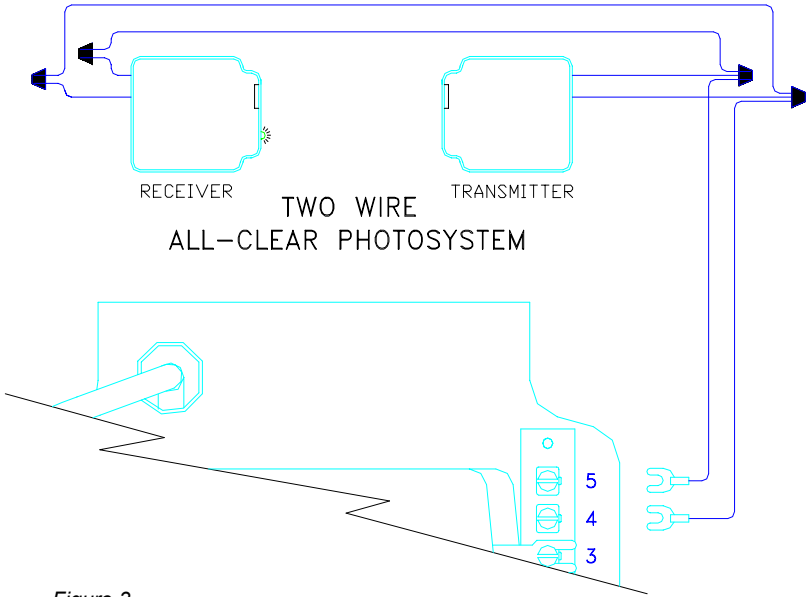

Figure 3

PHOTOCELL PARALLEL CONNECTION

108971

TWO WIRE ALL-CLEAR PHOTOSYSTEM

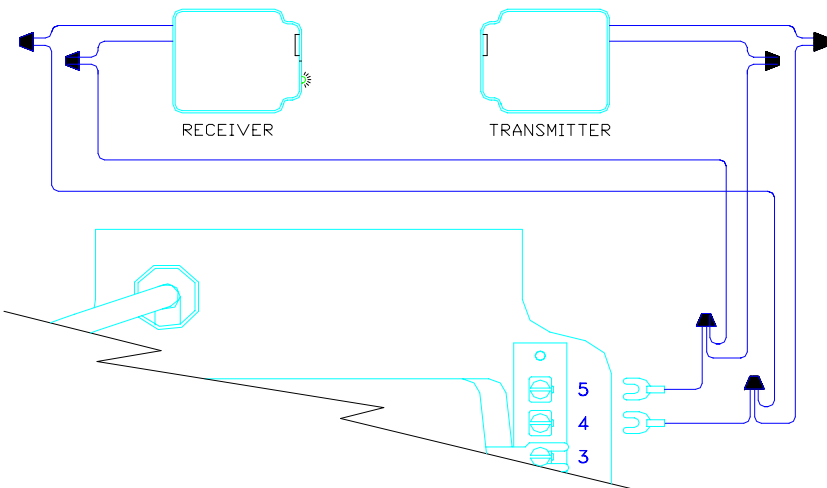

Figure 4

★ INSTALLATION OF ALL-CLEAR™ PHOTOSYSTEM

STEP 4 : Final Installation as follows:

- A. Attach the "U" brackets to the "L" brackets with a 1/4-20 carriage bolt, washer and hex nut (provided). Insert the bolt from the inside of the "U" bracket and hand tighten only at this time.
- B. Place the transmitter and receiver units into their respective "U" brackets. See Figure 5.
- C. Connect the interconnect wire pair to the garage door opener terminals marked "B" & "C" (for the 3000 & earlier Series operators), terminals "4" & "5" (for the 6000 Series units). Although not required, it is suggested that the "trace" be connected to Terminal B (3000 Series operators), or 4 (6000 Series operators). See Wiring Diagram, Figure 2 (shows 6000 Series configuration)

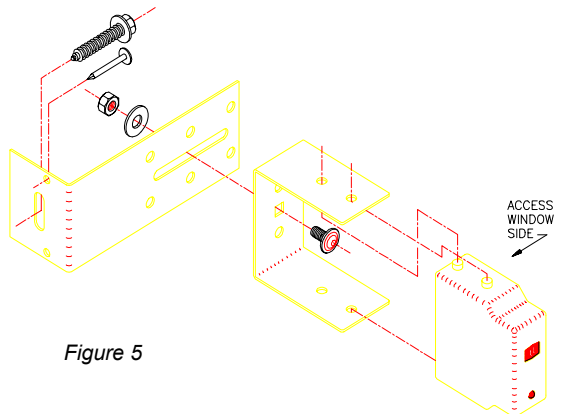

Figure 5

STEP 5 : Final Alignment and Test

- A. Reconnect the power to the Garage Door Opener. Keep a portable transmitter with you to control the garage door opener.
- B. Place a solid object one foot in front of the transmitter or receiver. The red LED should go **OFF** and remain **OFF** until the object is removed.
- C. **NOTE:** There may be a slight delay in returning to normal depending upon how long the photosystem was blocked.
- D. **Move to the center of the door. Make sure the red LED light is on. Move a solid object slowly through the beam. The LED should go OFF and then ON. If not, check the wire connections (see Step 3).**
- E. At this time set or recheck the down limit adjustment and reversing system adjustment of the garage door opener following the procedure outlined in your Allstar Residential Vehicular Garage Door Opener Installation and Instruction Manual. It is **VERY IMPORTANT** that the door opener's inherent features operate as intended before completing the photosystem tests.
- F. Place an opener insert box or a similar object (at least six inches high) on the floor at the center of the door. Now, attempt to close the door. **The door should NOT close** from the portable transmitter, but will close with constant pressure from the mechanical push button.
- G. Remove the obstruction from the photosystem beam's path. Close the door. Toward the bottom of the doors downward movement, **CAREFULLY** move a solid object across the path of the beam at the center of the door. **The door should STOP, pause for approximately one second and OPEN.** Retest, breaking the beam one foot in front of both the transmitter and receiver unit while the door is moving downward. **The door must STOP and OPEN each time. If not, re-align the photosystem until proper operation is obtained.**
- H. Tighten all mounting screws and bolts.